

1. Types, design features, and characteristics

Since the rolling elements in cylindrical roller bearings make line contact with raceways, these bearings can accommodate heavy radial loads. The rollers are guided by ribs on either the inner or outer ring, therefore these bearings are also suitable for high speed applications. Furthermore, cylindrical roller bearings are separable, and relatively easy to install and disassemble even when interference fits are required.

Among the various types of cylindrical roller bearings, Type E has a high load capacity and its boundary dimensions are identical to standard type. HT type has a

large axial load capacity, and HL type provides extended wear life in conditions where the development of a lubricating film inside the bearing is difficult.

Double and multiple row bearing arrangements are also available.

For extremely heavy load applications, the non-separable full complement SL type bearing offers special advantages.

Table 1 shows the various types and characteristics of single row cylindrical roller bearings. **Table 2** shows the characteristics of non-standard type cylindrical roller bearings.

Table 1 Cylindrical roller bearing types and characteristics

Type code	Design	Characteristics
NU type N type	 NU type N type	<ul style="list-style-type: none"> • NU type outer rings have double ribs; outer ring and roller as well as cage can be separated from inner ring. N type inner ring have double ribs; inner ring and roller as well as cage can be separated from outer ring. • Unable to accommodate even the lightest axial loads. • This type is extremely suitable for, and widely used as, the floating side bearing.
NJ type NF type	 NJ type NF type	<ul style="list-style-type: none"> • NJ type has double ribs on outer ring, single rib on inner ring; NF type has single rib on outer ring, and double rib on inner ring. • Can receive single direction axial loads. • When there is no distinction between the fixed side and floating side bearing, can be used as a pair in close proximity.
NUP type NH type (NJ + HJ)	 NUP type NH type	<ul style="list-style-type: none"> • NUP type has a collar ring attached to the ribless side of the inner ring; NH type is NJ type with an L type collar ring attached. All of these collar rings are separable, and therefore it is necessary to fix the inner ring axially. • Can accommodate axial loads in either direction. • Widely used as the shaft's fixed-side bearing.



Table 2 Non-standard type cylindrical roller bearing characteristics

Bearing type	Characteristics
E Type cylindrical roller bearing	<ul style="list-style-type: none"> Boundary dimensions are the same as the standard type, but the diameter, length and number of the rollers have been increased, as well as load capacity. Identified by addition of "E" to end of basic roller number. Enables compact design due to its high load rating. Rollers' inscribed circle diameter differs from standard type rollers and therefore cannot be interchanged. <p>Remarks: In the dimension tables, both E type and standard type are listed, but in the future JIS will change to E type.</p>
Large axial load use cylindrical roller bearings (HT type)	<ul style="list-style-type: none"> Can accommodate larger axial loads than standard type thanks to improved geometry of the rib roller end surface. Please consult NTN Engineering concerning the many factors which require consideration, such as load, lubricant, and installation conditions.
Double row cylindrical roller bearings	<ul style="list-style-type: none"> NN type and NNU type available. Widely used for applications requiring thin-walled bearings, such the main shafts of machine tools, rolling machine rollers, and in printing equipment. Internal radial clearance is adjusted for the spindle of machine tools by pressing the tapered bore of the inner ring on a tapered shaft.
Four row cylindrical roller bearings	<ul style="list-style-type: none"> Used mainly in the necks of rolling machine rollers; designed for maximum rated load to accommodate the severely limited space in the roller neck section of such equipment. Many varieties exist, including sealed types, which have been specially designed for high speed use, to prevent creeping, provide dust and water proofing properties, etc. Contact NTN Engineering.
SL type cylindrical roller bearings	<ul style="list-style-type: none"> Full complement roller bearing capable of handling heavy loads. Consult NTN Engineering regarding special application designs for SL type cylindrical roller bearings.

2. Standard cage types

Table 3 shows the standard varieties for cylindrical roller bearings.

Table 3 Standard cage types

Bearing series	Molded resin cage	Pressed cage	Machined cage
NU10	—	—	1005~10/500
NU 2 NU2E	— 204E~218E	208~230 —	232~264 219E~240E
NU22 NU22E	— 2204E~2218E	2208~2230 —	2232~2264 2219E~2240E
NU3 NU3E	— 304E~314E	308~324 —	326~356 315E~332E
NU23 NU23E	— 2304E~2311E	2308~2320 —	2322~2356 2312E~2332E
NU4	—	405~416	—

The basic load ratings listed in the dimension charts correspond to values achieved with the standard cages listed in Table 3. Furthermore, please note that even for the identical bearing, in cases where the number of rolling elements or the cage type differs, the basic rated load will also differ from the values listed in the dimension charts.

- Note: 1) Within the same bearing series, cage type is identical even if the type code (NJ, NUP, N, NF) differs.
- 2) For high speed and other special applications, machined cages can be manufactured when necessary. Consult NTN Engineering.
- 3) Among E type bearings (those using molded resin cages), certain varieties may also use pressed cages. Consult NTN Engineering.
- 4) Although machined cages are standard for two row and four row cylindrical roller bearings, molded resin cages may also be used in some of these bearings for machine tool applications.
- 5) **Due to their material properties, molded resin cages cannot be used in applications where temperatures exceed 120°C. #04 - #07 however use resin material with superior ability to withstand heat and high temperatures, which are capable of withstanding temperatures up to 150°C.**
- 6) Formed resin cages capable of withstanding temperatures up to 150°C can be manufactured by request for type E (formed resin cage) of #08 or greater. For information, please contact NTN Engineering.

3. Allowable misalignment

Although values vary somewhat depending on bearing type and internal specifications, under general load conditions, to avoid the occurrence of edge loading, allowable misalignments have been set as follows:

Bearing width series 0 or 1:.....	0.001 rad (3.5')
Bearing width series 2:.....	0.0005 rad (1.5')
Double row cylindrical roller bearings ①:.....	0.0005 rad (1.5')

① Does not include high precision bearings for machine tool main shaft applications.

4. Allowable axial load for cylindrical roller bearings

Cylindrical roller bearings with ribs on the inner and outer rings are capable of simultaneously bearing a radial load and an axial load of a certain degree. Unlike basic load ratings based on rolling fatigue, allowable axial load is determined by heat produced on the sliding surface between the ends of the rollers and rib, seizure and wear. Allowable axial load when center axial load is applied is approximately determined by formula (1), which is based upon experience and testing.

$$P_t = k \cdot d^2 \cdot P_z \dots\dots\dots(1)$$

Where:

- P_t : Allowable axial load when rotating N {kgf}
- k : Factor determined by internal design of bearing (see **Table 4**)
- d : Bearing bore mm
- P_z : Allowable surface pressure of rib MPa {kgf/mm²} (see **Fig. 1**)

If axial load is greater than radial load, the rollers will not rotate properly. The allowable axial load therefore must not exceed the value for $F_{a \max}$ given in **Table 4**.

The following are also important to operate the bearing smoothly under axial load:

- (1) Do not make the internal radial clearance any larger than necessary.
- (2) Use lubricant with extreme pressure additive.
- (3) Make the shoulder of the housing and shaft high enough for the rib of the bearing.
- (4) If the bearing is to support an extreme axial load, mounting precision should be improved and the bearing should rotate slowly before actual use.

If large cylindrical roller bearings (bore of 300 mm or more)

are to support an axial load or moment load simultaneously, please contact NTN Engineering.

NTN Engineering also offers cylindrical roller bearings for high axial loads (HT type). For details, please contact NTN Engineering.

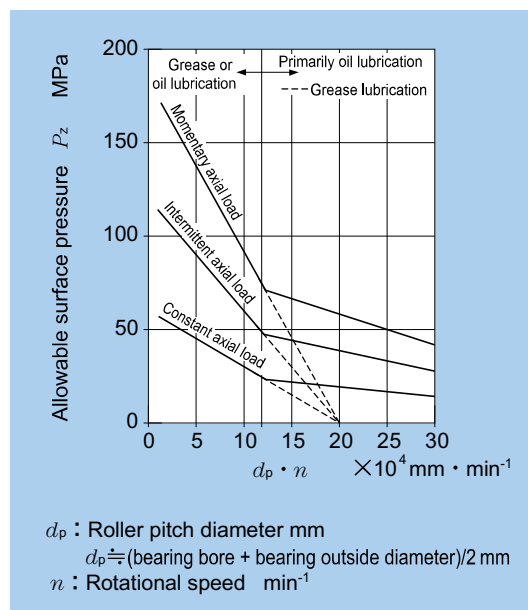
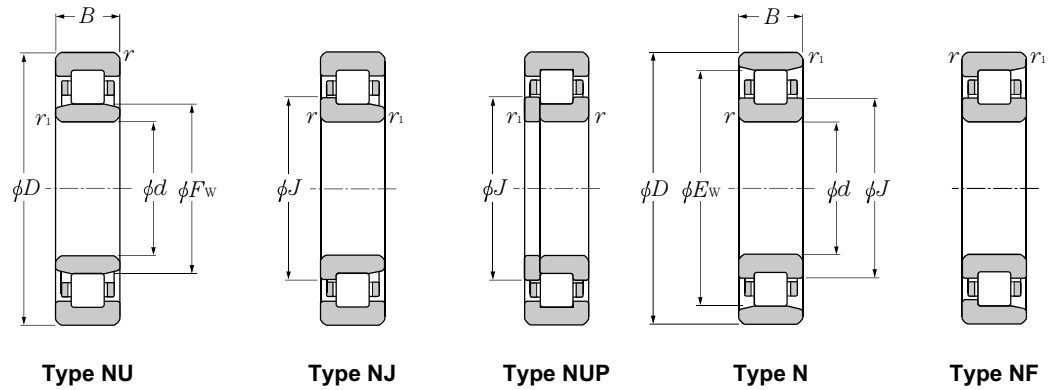

Fig. 1 Allowable surface pressure of rib

Table 4 Factor k values and allowable axial load ($F_{a \max}$)

Bearing series	k	$F_{a \max}$
NJ, NUP10	0.040	$0.4F_r$
NJ, NUP, NF, NH2, NJ, NUP, NH22		
NJ, NUP, NF, NH3, NJ, NUP, NH23		
NJ, NUP, NH2E, NJ, NUP, NH22E	0.065	$0.4F_r$
NJ, NUP, NH3E, NJ, NUP, NH23E	0.050	$0.4F_r$
NJ, NUP, NH4,	0.080	$0.4F_r$
SL01-48	0.100	$0.4F_r$
SL01-49	0.022	$0.2F_r$
SL04-50	0.034	$0.2F_r$
	0.044	$0.2F_r$





d 20 ~ 40mm

d	Boundary dimensions				Basic load ratings				Limiting speeds ¹⁾		Bearing numbers ²⁾			
	D	B	mm		kN		kgf		min ⁻¹		type NU	type NJ	type NUP	type N
			$r_{s\ min}^{(3)}$	$r_{1s\ min}^{(3)}$	C_r	C_{or}	C_r	C_{or}	grease	oil				
20	47	14	1	0.6	25.7	22.6	2 620	2 310	15 000	18 000	NU204E	NJ	NUP	—
	47	18	1	0.6	30.5	28.3	3 100	2 890	14 000	16 000	NU2204E	NJ	NUP	—
	52	15	1.1	0.6	31.5	26.9	3 200	2 740	13 000	15 000	NU304E	NJ	NUP	—
	52	21	1.1	0.6	42.0	39.0	4 300	3 950	12 000	14 000	NU2304E	NJ	NUP	—
25	47	12	0.6	0.3	15.1	14.1	1 540	1 430	16 000	19 000	NU1005	NJ	NUP	N
	52	15	1	0.6	29.3	27.7	2 990	2 830	13 000	15 000	NU205E	NJ	NUP	—
	52	18	1	0.6	35.0	34.5	3 550	3 550	11 000	13 000	NU2205E	NJ	NUP	—
	62	17	1.1	1.1	41.5	37.5	4 250	3 800	11 000	13 000	NU305E	NJ	NUP	—
	62	24	1.1	1.1	57.0	56.0	5 800	5 700	9 700	11 000	NU2305E	NJ	NUP	—
	80	21	1.5	1.5	46.5	40.0	4 750	4 050	8 500	10 000	NU405	NJ	NUP	N
30	55	13	1	0.6	19.7	19.6	2 000	2 000	14 000	16 000	NU1006	NJ	NUP	N
	62	16	1	0.6	39.0	37.5	4 000	3 800	11 000	13 000	NU206E	NJ	NUP	—
	62	20	1	0.6	49.0	50.0	5 000	5 100	9 700	11 000	NU2206E	NJ	NUP	—
	72	19	1.1	1.1	53.0	50.0	5 400	5 100	9 300	11 000	NU306E	NJ	NUP	—
	72	27	1.1	1.1	74.5	77.5	7 600	7 900	8 300	9 700	NU2306E	NJ	NUP	—
	90	23	1.5	1.5	62.5	55.0	6 400	5 600	7 300	8 500	NU406	NJ	NUP	N
35	62	14	1	0.6	22.6	23.2	2 310	2 360	12 000	15 000	NU1007	NJ	NUP	N
	72	17	1.1	0.6	50.5	50.0	5 150	5 100	9 500	11 000	NU207E	NJ	NUP	—
	72	23	1.1	0.6	61.5	65.5	6 300	6 650	8 500	10 000	NU2207E	NJ	NUP	—
	80	21	1.5	1.1	71.0	71.0	7 200	7 200	8 100	9 600	NU307E	NJ	NUP	—
	80	31	1.5	1.1	99.0	109	10 100	11 100	7 200	8 500	NU2307E	NJ	NUP	—
	100	25	1.5	1.5	75.5	69.0	7 700	7 050	6 400	7 500	NU407	NJ	NUP	N
40	68	15	1	0.6	27.3	29.0	2 780	2 950	11 000	13 000	NU1008	NJ	NUP	N
	80	18	1.1	1.1	43.5	43.0	4 450	4 350	9 400	11 000	NU208	NJ	NUP	N
	80	18	1.1	1.1	55.5	55.5	5 700	5 650	8 500	10 000	NU208E	NJ	NUP	—
	80	23	1.1	1.1	58.0	62.0	5 950	6 300	8 500	10 000	NU2208	NJ	NUP	N
	80	23	1.1	1.1	72.5	77.5	7 400	7 900	7 600	8 900	NU2208E	NJ	NUP	—
	90	23	1.5	1.5	58.5	57.0	6 000	5 800	8 000	9 400	NU308	NJ	NUP	N
	90	23	1.5	1.5	83.0	81.5	8 500	8 300	7 200	8 500	NU308E	NJ	NUP	—
	90	33	1.5	1.5	82.5	88.0	8 400	8 950	7 000	8 200	NU2308	NJ	NUP	N
	90	33	1.5	1.5	114	122	11 600	12 500	6 400	7 500	NU2308E	NJ	NUP	—
	110	27	2	2	95.5	89.0	9 750	9 100	5 700	6 700	NU408	NJ	NUP	N

1) This value achieved with machined cages; when pressed cages are used, 80% of this value is acceptable.

2) Production switched to E type only for bearing number for which there is no standard form.

3) Minimal allowable dimension for chamfer dimension r or r_1 .

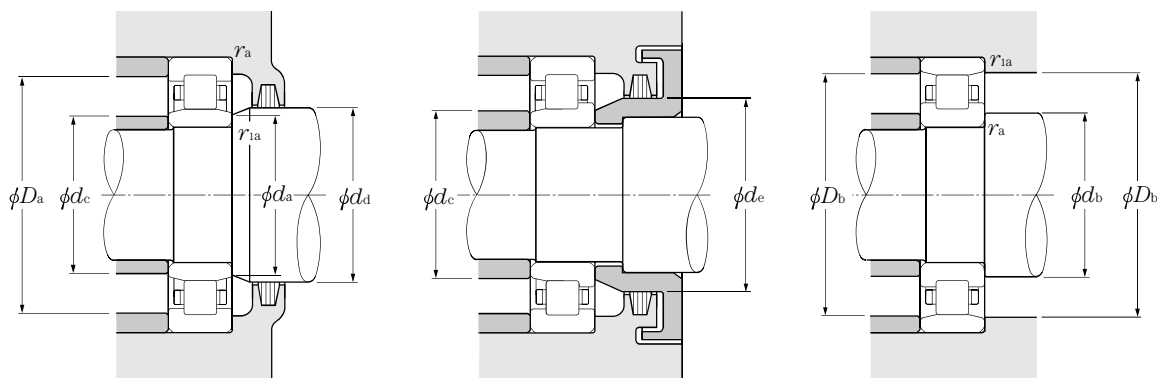

Dynamic equivalent radial load

$$P_r = F_r$$

Static equivalent radial load

$$P_{0r} = F_r$$

type	Dimensions			Abutment and fillet dimensions										Mass	
	F_w	E_w	J	d_a min	d_b min	d_c max	d_d min	d_e min	D_a max	D_b max	$\min^4)$	r_{as} max	r_{1as} max	type NU (approx.)	type N
—	26.5	—	29.5	24	—	26	29	32	42	—	—	1	0.6	0.122	—
—	26.5	—	29.5	24	—	26	29	32	42	—	—	1	0.6	0.158	—
—	27.5	—	31.1	24	—	27	30	33	45.5	—	—	1	0.6	0.176	—
—	27.5	—	31.1	24	—	27	30	33	45.5	—	—	1	0.6	0.242	—
—	30.5	41.5	32.7	27	29	30	32	33	43	45	42.5	0.6	0.3	0.092	0.091
—	31.5	—	34.5	29	—	31	34	37	47	—	—	1	0.6	0.151	—
—	31.5	—	34.5	29	—	31	34	37	47	—	—	1	0.6	0.186	—
—	34	—	38	31.5	—	33	37	40	55.5	—	—	1	1	0.275	—
—	34	—	38	31.5	—	33	37	40	55.5	—	—	1	1	0.386	—
NF	38.8	62.8	43.6	33	33	38	41	46	72	72	64	1.5	1.5	0.55	0.536
—	36.5	48.5	38.9	34	35	35	38	39.5	50	51	49.5	1	0.6	0.13	0.128
—	37.5	—	41.1	34	—	37	40	44	57	—	—	1	0.6	0.226	—
—	37.5	—	41.1	34	—	37	40	44	57	—	—	1	0.6	0.297	—
—	40.5	—	44.9	36.5	—	40	44	48	65.5	—	—	1	1	0.398	—
—	40.5	—	44.9	36.5	—	40	44	48	65.5	—	—	1	1	0.58	—
NF	45	73	50.5	38	38	44	47	52	82	82	74	1.5	1.5	0.751	0.732
—	42	55	44.6	39	40	41	44	45	57	58	56	1	0.6	0.179	0.176
—	44	—	48	39	—	43	46	50	65.5	—	—	1	0.6	0.327	—
—	44	—	48	39	—	43	46	50	65.5	—	—	1	0.6	0.455	—
—	46.2	—	51	41.5	—	45	48	53	72	—	—	1.5	1	0.545	—
—	46.2	—	51	41.5	—	45	48	53	72	—	—	1.5	1	0.78	—
NF	53	83	59	43	43	52	55	61	92	92	84	1.5	1.5	0.99	0.965
—	47	61	49.8	44	45	46	49	50.5	63	64	62	1	0.6	0.22	0.217
NF	50	70	54.2	46.5	46.5	49	52	56	73.5	73.5	72	1	1	0.378	0.37
—	49.5	—	53.9	46.5	—	49	52	56	73.5	—	—	1	1	0.426	—
—	50	70	54.2	46.5	46.5	49	52	56	73.5	73.5	72	1	1	0.49	0.48
—	49.5	—	53.9	46.5	—	49	52	56	73.5	—	—	1	1	0.552	—
NF	53.5	77.5	58.4	48	48	51	55	60	82	82	80	1.5	1.5	0.658	0.643
—	52	—	57.6	48	—	51	55	60	82	—	—	1.5	1.5	0.754	—
—	53.5	77.5	58.4	48	48	51	55	60	82	82	80	1.5	1.5	0.951	0.932
—	52	—	57.6	48	—	51	55	60	82	—	—	1.5	1.5	1.06	—
NF	58	92	64.8	49	49	57	60	67	101	101	93	2	2	1.3	1.27

4) Does not apply to side of the outer ring rib of type **NF** bearings.

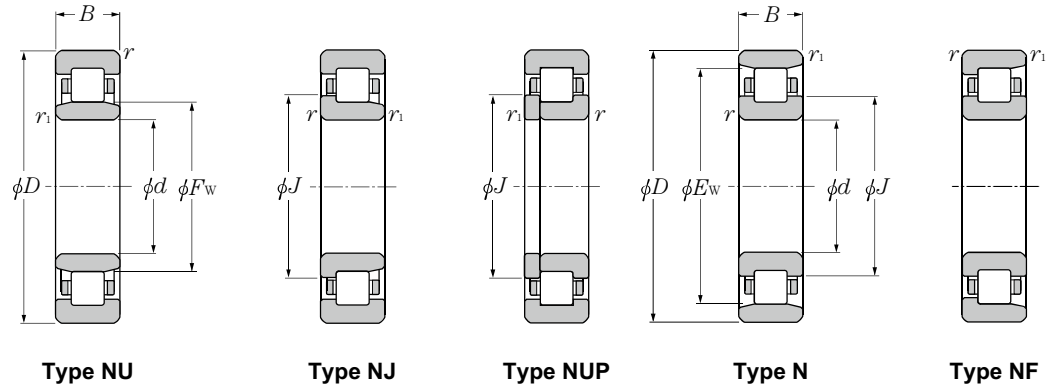

d 45 ~ 60mm

d	Boundary dimensions				Basic load ratings				Limiting speeds ¹⁾		Bearing numbers ²⁾			
	mm				kN		kgf		min ⁻¹		type	type	type	type
	D	B	r _{s min} ³⁾	r _{1s min} ³⁾	C _r	C _{or}	C _r	C _{or}	grease	oil	NU	NJ	NUP	N
45	75	16	1	0.6	31.0	34.0	3 200	3 450	9 900	12 000	NU1009	NJ	NUP	N
	85	19	1.1	1.1	46.0	47.0	4 700	4 800	8 400	9 900	NU209	NJ	NUP	N
	85	19	1.1	1.1	63.0	66.5	6 450	6 800	7 600	9 000	NU209E	NJ	NUP	—
	85	23	1.1	1.1	61.5	68.0	6 250	6 900	7 600	9 000	NU2209	NJ	NUP	N
	85	23	1.1	1.1	76.0	84.5	7 750	8 600	6 800	8 000	NU2209E	NJ	NUP	—
	100	25	1.5	1.5	74.0	71.0	7 550	7 250	7 200	8 400	NU309	NJ	NUP	N
	100	25	1.5	1.5	97.5	98.5	9 950	10 000	6 500	7 600	NU309E	NJ	NUP	—
	100	36	1.5	1.5	99.0	104	10 100	10 600	6 300	7 400	NU2309	NJ	NUP	N
	100	36	1.5	1.5	137	153	14 000	15 600	5 700	6 800	NU2309E	NJ	NUP	—
	120	29	2	2	107	102	10 900	10 400	5 100	6 000	NU409	NJ	NUP	N
50	80	16	1	0.6	32.0	36.0	3 300	3 700	8 900	11 000	NU1010	NJ	NUP	N
	90	20	1.1	1.1	48.0	51.0	4 900	5 200	7 600	9 000	NU210	NJ	NUP	N
	90	20	1.1	1.1	66.0	72.0	6 750	7 350	6 900	8 100	NU210E	NJ	NUP	—
	90	23	1.1	1.1	64.0	73.5	6 550	7 500	6 900	8 100	NU2210	NJ	NUP	N
	90	23	1.1	1.1	79.5	91.5	8 100	9 350	6 200	7 300	NU2210E	NJ	NUP	—
	110	27	2	2	87.0	86.0	8 850	8 800	6 500	7 700	NU310	NJ	NUP	N
	110	27	2	2	110	113	11 200	11 500	5 900	6 900	NU310E	NJ	NUP	—
	110	40	2	2	121	131	12 300	13 400	5 700	6 700	NU2310	NJ	NUP	N
	110	40	2	2	163	187	16 600	19 000	5 200	6 100	NU2310E	NJ	NUP	—
	130	31	2.1	2.1	129	124	13 200	12 600	4 700	5 500	NU410	NJ	NUP	N
55	90	18	1.1	1	37.5	44.0	3 850	4 450	8 200	9 700	NU1011	NJ	NUP	N
	100	21	1.5	1.1	58.0	62.5	5 900	6 350	6 900	8 200	NU211	NJ	NUP	N
	100	21	1.5	1.1	82.5	93.0	8 400	9 500	6 300	7 400	NU211E	NJ	NUP	—
	100	25	1.5	1.1	75.5	87.0	7 700	8 900	6 300	7 400	NU2211	NJ	NUP	N
	100	25	1.5	1.1	97.0	114	9 900	11 700	5 600	6 600	NU2211E	NJ	NUP	—
	120	29	2	2	111	111	11 300	11 400	5 900	7 000	NU311	NJ	NUP	N
	120	29	2	2	137	143	14 000	14 600	5 300	6 300	NU311E	NJ	NUP	—
	120	43	2	2	148	162	15 100	16 500	5 200	6 100	NU2311	NJ	NUP	N
	120	43	2	2	201	233	20 500	23 800	4 700	5 600	NU2311E	NJ	NUP	—
	140	33	2.1	2.1	139	138	14 200	14 100	4 300	5 000	NU411	NJ	NUP	N
60	95	18	1.1	1	40.0	48.5	4 100	4 950	7 500	8 800	NU1012	NJ	NUP	N
	110	22	1.5	1.5	68.5	75.0	7 000	7 650	6 400	7 600	NU212	NJ	NUP	N
	110	22	1.5	1.5	97.5	107	9 950	10 900	5 800	6 800	NU212E	NJ	NUP	—
	110	28	1.5	1.5	96.0	116	9 800	11 800	5 800	6 800	NU2212	NJ	NUP	N

1) This value achieved with machined cages; when pressed cages are used, 80% of this value is acceptable.

2) Production switched to E type only for bearing number for which there is no standard form.

3) Minimal allowable dimension for chamfer dimension r or r_1 .

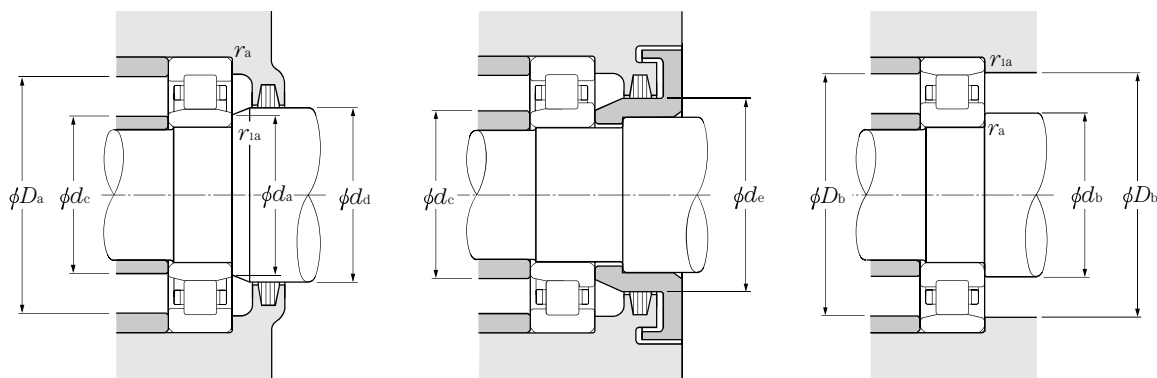

Dynamic equivalent radial load

$$P_r = F_r$$

Static equivalent radial load

$$P_{0r} = F_r$$

type	Dimensions			Abutment and fillet dimensions										Mass	
	F_w	E_w	J	d_a min	d_b min	d_c max	d_d min	d_e min	D_a max	D_b max	$\min^4)$	r_{as} max	r_{1as} max	type NU (approx.)	type N
—	52.5	67.5	55.5	49	50	52	54	56	70	71	68.5	1	0.6	0.28	0.276
NF	55	75	59	51.5	51.5	54	57	61	78.5	78.5	77	1	1	0.432	0.423
—	54.5	—	58.9	51.5	—	54	57	61	78.5	—	—	1	1	0.495	—
—	55	75	59	51.5	51.5	54	57	61	78.5	78.5	77	1	1	0.53	0.52
—	54.5	—	58.9	51.5	—	54	57	61	78.5	—	—	1	1	0.6	—
NF	58.5	86.5	64	53	53	57	60	66	92	92	89	1.5	1.5	0.877	0.857
—	58.5	—	64.5	53	—	57	60	66	92	—	—	1.5	1.5	0.996	—
—	58.5	86.5	64	53	53	57	60	66	92	92	89	1.5	1.5	1.27	1.24
—	58.5	—	64.5	53	—	57	60	66	92	—	—	1.5	1.5	1.41	—
NF	64.5	100.5	71.8	54	54	63	66	74	111	111	102	2	2	1.62	1.58
—	57.5	72.5	60.5	54	55	57	59	61	75	76	73.5	1	0.6	0.295	0.291
NF	60.4	80.4	64.6	56.5	56.5	58	62	67	83.5	83.5	83	1	1	0.47	0.46
—	59.5	—	63.9	56.5	—	58	62	67	83.5	—	—	1	1	0.54	—
—	60.4	80.4	64.6	56.5	56.5	58	62	67	83.5	83.5	83	1	1	0.571	0.56
—	59.5	—	63.9	56.5	—	58	62	67	83.5	—	—	1	1	0.652	—
NF	65	95	71	59	59	63	67	73	101	101	98	2	2	1.14	1.11
—	65	—	71.4	59	—	63	67	73	101	—	—	2	2	1.3	—
—	65	95	71	59	59	63	67	73	101	101	98	2	2	1.7	1.67
—	65	—	71.4	59	—	63	67	73	101	—	—	2	2	1.9	—
NF	70.8	110.8	78.8	61	61	69	73	81	119	119	112	2	2	2.02	1.97
—	64.5	80.5	67.7	60	61.5	63	66	68.5	83.5	85	81.5	1	1	0.442	0.435
NF	66.5	88.5	70.8	61.5	63	65	68	73	92	93.5	91	1.5	1	0.638	0.626
—	66	—	70.8	61.5	—	65	68	73	92	—	—	1.5	1	0.718	—
—	66.5	88.5	70.8	61.5	63	65	68	73	92	93.5	91	1.5	1	0.773	0.758
—	66	—	70.8	61.5	—	65	68	73	92	—	—	1.5	1	0.968	—
NF	70.5	104.5	77.2	64	64	69	72	80	111	111	107	2	2	1.45	1.42
—	70.5	—	77.7	64	—	69	72	80	111	—	—	2	2	1.65	—
—	70.5	104.5	77.2	64	64	69	72	80	111	111	107	2	2	2.17	2.13
—	70.5	—	77.7	64	—	69	72	80	111	—	—	2	2	2.37	—
NF	77.2	117.2	85.2	66	66	76	79	87	129	129	119	2	2	2.48	2.42
—	69.5	85.5	72.7	65	66.5	68	71	73.5	88.5	90	86.5	1	1	0.474	0.467
NF	73.5	97.5	78.4	68	68	71	75	80	102	102	100	1.5	1.5	0.818	0.802
—	72	—	77.6	68	—	71	75	80	102	—	—	1.5	1.5	0.923	—
—	73.5	97.5	78.4	68	68	71	75	80	102	102	100	1.5	1.5	1.06	1.04

4) Does not apply to side of the outer ring rib of type **NF** bearings.

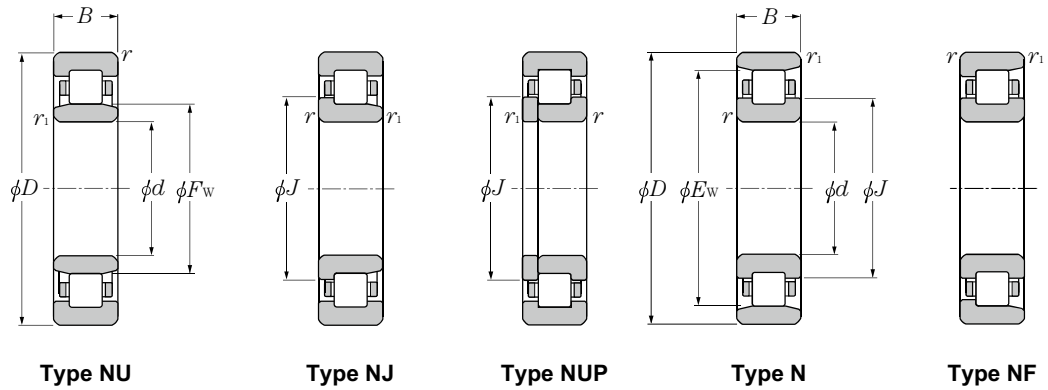

d 60 ~ 75mm

d	Boundary dimensions				Basic load ratings				Limiting speeds ¹⁾		Bearing numbers ²⁾			
	mm				kN		kgf		min ⁻¹		type NU	type NJ	type NUP	type N
	D	B	r _{s min} ³⁾	r _{1s min} ³⁾	C _r	C _{or}	C _r	C _{or}	grease	oil				
60	110	28	1.5	1.5	131	157	13 400	16 000	5 200	6 100	NU2212E	NJ	NUP	—
	130	31	2.1	2.1	124	126	12 600	12 900	5 500	6 500	NU312	NJ	NUP	N
	130	31	2.1	2.1	150	157	15 200	16 000	4 900	5 800	NU312E	NJ	NUP	—
	130	46	2.1	2.1	169	188	17 200	19 200	4 800	5 700	NU2312	NJ	NUP	N
	130	46	2.1	2.1	222	262	22 700	26 700	4 400	5 200	NU2312E	NJ	NUP	—
	150	35	2.1	2.1	167	168	17 100	17 200	3 900	4 600	NU412	NJ	NUP	N
65	100	18	1.1	1	41.0	51.0	4 200	5 200	7 000	8 200	NU1013	NJ	NUP	N
	120	23	1.5	1.5	84.0	94.5	8 550	9 650	5 900	7 000	NU213	NJ	NUP	N
	120	23	1.5	1.5	108	119	11 000	12 100	5 400	6 300	NU213E	NJ	NUP	—
	120	31	1.5	1.5	120	149	12 200	15 200	5 400	6 300	NU2213	NJ	NUP	N
	120	31	1.5	1.5	149	181	15 200	18 400	4 800	5 600	NU2213E	NJ	NUP	—
	140	33	2.1	2.1	135	139	13 800	14 200	5 100	6 000	NU313	NJ	NUP	N
	140	33	2.1	2.1	181	191	18 400	19 500	4 600	5 400	NU313E	NJ	NUP	—
	140	48	2.1	2.1	188	212	19 100	21 700	4 400	5 200	NU2313	NJ	NUP	N
	140	48	2.1	2.1	248	287	25 200	29 300	4 100	4 800	NU2313E	NJ	NUP	—
160	37	2.1	2.1	182	186	18 600	19 000	3 600	4 300	NU413	NJ	NUP	N	
70	110	20	1.1	1	58.5	70.5	5 950	7 200	6 500	7 600	NU1014	NJ	NUP	N
	125	24	1.5	1.5	83.5	95.0	8 500	9 700	5 500	6 500	NU214	NJ	NUP	N
	125	24	1.5	1.5	119	137	12 100	14 000	5 000	5 900	NU214E	NJ	NUP	—
	125	31	1.5	1.5	119	151	12 200	15 400	5 000	5 900	NU2214	NJ	NUP	N
	125	31	1.5	1.5	156	194	15 900	19 800	4 500	5 200	NU2214E	NJ	NUP	—
	150	35	2.1	2.1	158	168	16 100	17 200	4 700	5 500	NU314	NJ	NUP	N
	150	35	2.1	2.1	205	222	20 900	22 600	4 200	5 000	NU314E	NJ	NUP	—
	150	51	2.1	2.1	223	262	22 700	26 700	4 100	4 800	NU2314	NJ	NUP	N
	150	51	2.1	2.1	274	325	27 900	33 000	3 800	4 400	NU2314E	NJ	NUP	—
	180	42	3	3	228	236	23 200	24 000	3 400	4 000	NU414	NJ	NUP	N
75	115	20	1.1	1	60.0	74.5	6 100	7 600	6 100	7 100	NU1015	NJ	NUP	N
	130	25	1.5	1.5	96.5	111	9 850	11 300	5 100	6 000	NU215	NJ	NUP	N
	130	25	1.5	1.5	130	156	13 300	16 000	4 700	5 500	NU215E	NJ	NUP	—
	130	31	1.5	1.5	130	162	13 200	16 500	4 700	5 500	NU2215	NJ	NUP	N
	130	31	1.5	1.5	162	207	16 500	21 100	4 200	4 900	NU2215E	NJ	NUP	—
	160	37	2.1	2.1	190	205	19 400	20 900	4 400	5 200	NU315	NJ	NUP	N
	160	37	2.1	2.1	240	263	24 500	26 800	4 000	4 700	NU315E	NJ	NUP	—
	160	55	2.1	2.1	258	300	26 300	31 000	3 800	4 500	NU2315	NJ	NUP	N

1) This value achieved with machined cages; when pressed cages are used, 80% of this value is acceptable.

2) Production switched to E type only for bearing number for which there is no standard form.

3) Minimal allowable dimension for chamfer dimension r or r_1 .

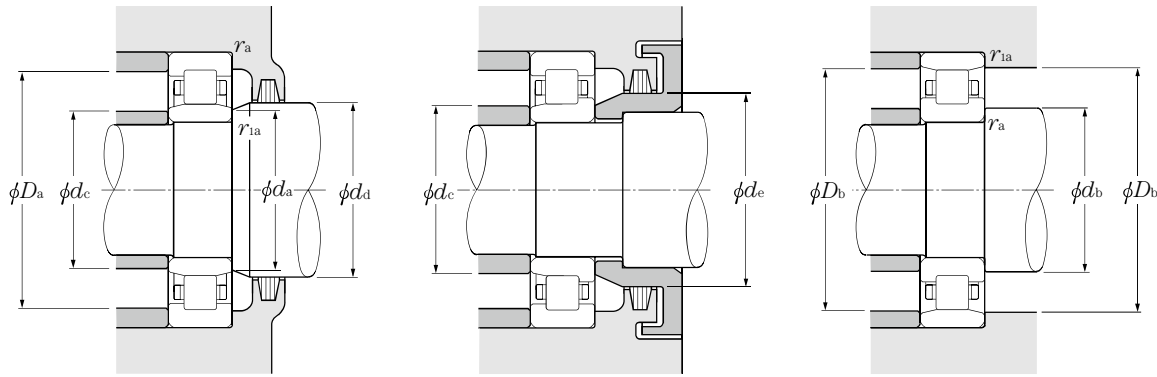

Dynamic equivalent radial load
 $P_r = F_r$

Static equivalent radial load
 $P_{0r} = F_r$

type	Dimensions			Abutment and fillet dimensions										Mass	
	mm			d_a min	d_b min	d_c max	d_d min	d_e min	D_a max	D_b max	D_b min ⁴⁾	r_{as} max	r_{1as} max	type NU (approx.)	type N
	F_w	E_w	J												
—	72	—	77.6	68	—	71	75	80	102	—	—	1.5	1.5	1.21	—
NF	77	113	84.2	71	71	75	79	86	119	119	116	2	2	1.8	1.76
—	77	—	84.6	71	—	75	79	86	119	—	—	2	2	2.05	—
—	77	113	84.2	71	71	75	79	86	119	119	116	2	2	2.71	2.66
—	77	—	84.6	71	—	75	79	86	119	—	—	2	2	2.96	—
NF	83	127	91.8	71	71	82	85	94	139	139	128	2	2	3	2.93
—	74.5	90.5	77.7	70	71.5	73	76	78.5	93.5	95	91.5	1	1	0.485	0.477
NF	79.6	105.6	84.8	73	73	77	81	87	112	112	108	1.5	1.5	1.02	1
—	78.5	—	84.5	73	—	77	81	87	112	—	—	1.5	1.5	1.21	—
—	79.6	105.6	84.8	73	73	77	81	87	112	112	108	1.5	1.5	1.4	1.37
—	78.5	—	84.5	73	—	77	81	87	112	—	—	1.5	1.5	1.6	—
NF	83.5	121.5	91	76	76	81	85	93	129	129	125	2	2	2.23	2.18
—	82.5	—	91	76	—	81	85	93	129	—	—	2	2	2.54	—
—	83.5	121.5	91	76	76	81	85	93	129	129	125	2	2	3.27	3.2
—	82.5	—	91	76	—	81	85	93	129	—	—	2	2	3.48	—
NF	89.3	135.3	98.5	76	76	88	91	100	149	149	137	2	2	3.6	3.5
—	80	100	84	75	76.5	78	82	85	103.5	105	101	1	1	0.699	0.689
NF	84.5	110.5	89.6	78	78	82	86	92	117	117	114	1.5	1.5	1.12	1.1
—	83.5	—	89.5	78	—	82	86	92	117	—	—	1.5	1.5	1.3	—
—	84.5	110.5	89.6	78	78	82	86	92	117	117	114	1.5	1.5	1.47	1.44
—	83.5	—	89.5	78	—	82	86	92	117	—	—	1.5	1.5	1.7	—
NF	90	130	98	81	81	87	92	100	139	139	134	2	2	2.71	2.65
—	89	—	98	81	—	87	92	100	139	—	—	2	2	3.1	—
—	90	130	98	81	81	87	92	100	139	139	134	2	2	3.98	3.9
—	89	—	98	81	—	87	92	100	139	—	—	2	2	4.25	—
NF	100	152	110.5	83	83	99	102	112	167	167	153	2.5	2.5	5.24	5.1
—	85	105	89	80	81.5	83	87	90	108.5	110	106	1	1	0.738	0.727
NF	88.5	116.5	94	83	83	87	90	96	122	122	120	1.5	1.5	1.23	1.21
—	88.5	—	94.5	83	—	87	90	96	122	—	—	1.5	1.5	1.41	—
—	88.5	116.5	94	83	83	87	90	96	122	122	120	1.5	1.5	1.55	1.52
—	88.5	—	94.5	83	—	87	90	96	122	—	—	1.5	1.5	1.79	—
NF	95.5	139.5	104.2	86	86	93	97	106	149	149	143	2	2	3.28	3.21
—	95	—	104.6	86	—	93	97	106	149	—	—	2	2	3.74	—
—	95.5	139.5	104.2	86	86	93	97	106	149	149	143	2	2	4.87	4.77

4) Does not apply to side of the outer ring rib of type **NF** bearings.

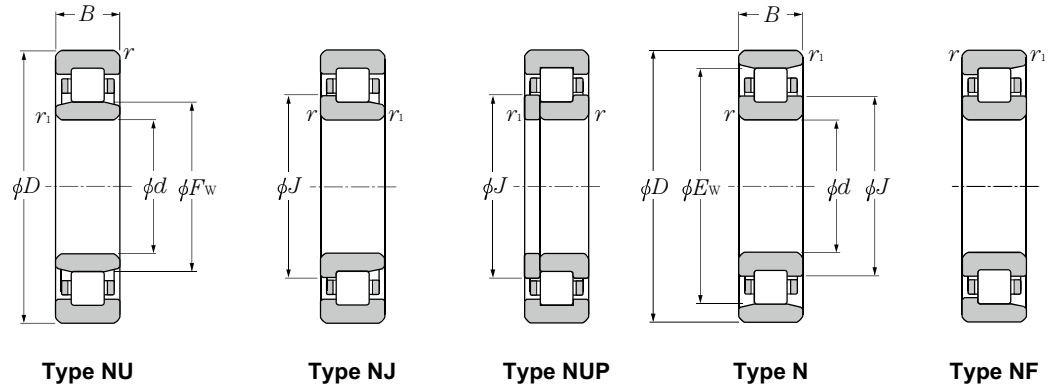

d 75 ~ 95mm

d	Boundary dimensions				Basic load ratings				Limiting speeds ¹⁾		Bearing numbers ²⁾			
	D	B	$r_{s \min}^{(3)}$	$r_{1s \min}^{(3)}$	dynamic		static		grease	oil	type	type	type	type
					C_r	C_{or}	C_r	C_{or}						
75	160	55	2.1	2.1	330	395	33 500	40 000	3 500	4 100	NU2315E	NJ	NUP	—
	190	45	3	3	262	274	26 800	27 900	3 200	3 700	NU415	NJ	NUP	N
80	125	22	1.1	1	72.5	90.5	7 400	9 250	5 700	6 700	NU1016	NJ	NUP	N
	140	26	2	2	106	122	10 800	12 500	4 800	5 700	NU216	NJ	NUP	N
	140	26	2	2	139	167	14 200	17 000	4 400	5 100	NU216E	NJ	NUP	—
	140	33	2	2	147	186	15 000	19 000	4 400	5 100	NU2216	NJ	NUP	N
	140	33	2	2	186	243	19 000	24 800	3 900	4 600	NU2216E	NJ	NUP	—
	170	39	2.1	2.1	190	207	19 400	21 100	4 100	4 800	NU316	NJ	NUP	N
	170	39	2.1	2.1	256	282	26 100	28 800	3 700	4 400	NU316E	NJ	NUP	—
	170	58	2.1	2.1	274	330	27 900	34 000	3 600	4 200	NU2316	NJ	NUP	N
	170	58	2.1	2.1	355	430	36 500	44 000	3 300	3 900	NU2316E	NJ	NUP	—
	200	48	3	3	299	315	30 500	32 000	3 000	3 500	NU416	NJ	NUP	N
85	130	22	1.1	1	74.5	95.5	7 600	9 750	5 400	6 300	NU1017	NJ	NUP	N
	150	28	2	2	120	140	12 300	14 300	4 500	5 300	NU217	NJ	NUP	N
	150	28	2	2	167	199	17 000	20 300	4 100	4 800	NU217E	NJ	NUP	—
	150	36	2	2	170	218	17 300	22 200	4 100	4 800	NU2217	NJ	NUP	N
	150	36	2	2	217	279	22 200	28 400	3 700	4 300	NU2217E	NJ	NUP	—
	180	41	3	3	212	228	21 600	23 300	3 900	4 600	NU317	NJ	NUP	N
	180	41	3	3	291	330	29 700	33 500	3 500	4 100	NU317E	NJ	NUP	—
	180	60	3	3	315	380	32 000	39 000	3 400	4 000	NU2317	NJ	NUP	N
	180	60	3	3	395	485	40 000	49 500	3 100	3 700	NU2317E	NJ	NUP	—
90	140	24	1.5	1.1	88.0	114	9 000	11 700	5 100	5 900	NU1018	NJ	NUP	N
	160	30	2	2	152	178	15 500	18 100	4 300	5 000	NU218	NJ	NUP	N
	160	30	2	2	182	217	18 500	22 200	3 900	4 600	NU218E	NJ	NUP	—
	160	40	2	2	197	248	20 100	25 300	3 900	4 600	NU2218	NJ	NUP	N
	160	40	2	2	242	315	24 700	32 000	3 500	4 100	NU2218E	NJ	NUP	—
	190	43	3	3	240	265	24 500	27 100	3 700	4 300	NU318	NJ	NUP	N
	190	43	3	3	315	355	32 000	36 000	3 300	3 900	NU318E	NJ	NUP	—
	190	64	3	3	325	395	33 500	40 000	3 200	3 800	NU2318	NJ	NUP	N
	190	64	3	3	435	535	44 500	54 500	2 900	3 400	NU2318E	NJ	NUP	—
95	145	24	1.5	1.1	90.5	120	9 250	12 300	4 800	5 600	NU1019	NJ	NUP	N
	170	32	2.1	2.1	166	195	16 900	19 900	4 000	4 700	NU219	NJ	NUP	N
	170	32	2.1	2.1	220	265	22 500	27 000	3 600	4 300	NU219E	NJ	NUP	—

1) This value achieved with machined cages; when pressed cages are used, 80% of this value is acceptable.

2) Production switched to E type only for bearing number for which there is no standard form.

3) Minimal allowable dimension for chamfer dimension r or r_1 .

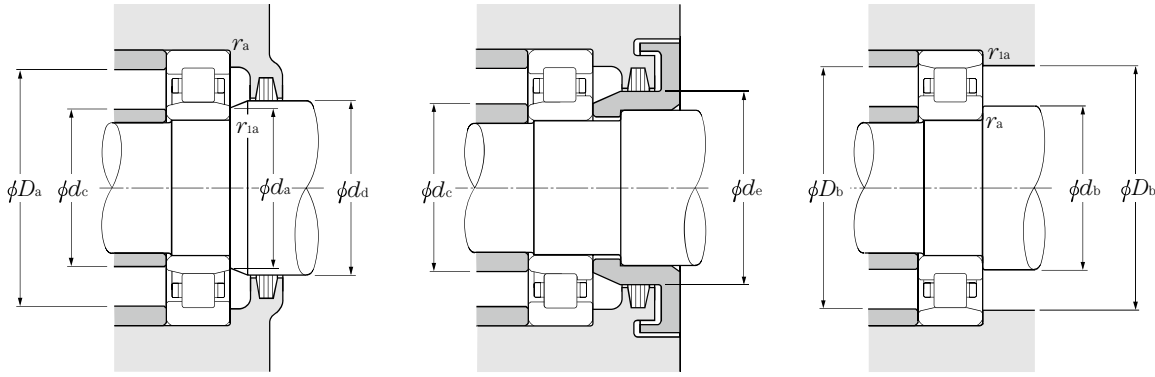

Dynamic equivalent radial load
 $P_r = F_r$

Static equivalent radial load
 $P_{0r} = F_r$

type	Dimensions			Abutment and fillet dimensions										Mass	
	F_w	E_w	J	d_a min	d_b min	d_c max	d_d min	d_e min	D_a max	D_b max	D_b min ⁴⁾	r_{as} max	r_{ias} max	type NU (approx.)	type N
NF	mm			mm										kg	
—	95	—	104.6	86	—	93	97	106	149	—	—	2	2	5.25	—
NF	104.5	160.5	116	88	88	103	107	118	177	177	162	2.5	2.5	6.22	6.06
—	91.5	113.5	95.9	85	86.5	90	94	97	118.5	120	114.5	1	1	0.98	0.965
NF	95.3	125.3	101.2	89	89	94	97	104	131	131	128	2	2	1.5	1.47
—	95.3	—	101.7	89	—	94	97	104	131	—	—	2	2	1.67	—
—	95.3	125.3	101.2	89	89	94	97	104	131	131	128	2	2	1.93	1.89
—	95.3	—	101.7	89	—	94	97	104	131	—	—	2	2	2.12	—
NF	103	147	111.8	91	91	99	105	114	159	159	151	2	2	3.86	3.77
—	101	—	111	91	—	99	105	114	159	—	—	2	2	4.22	—
—	103	147	111.8	91	91	99	105	114	159	159	151	2	2	5.79	5.67
—	101	—	111	91	—	99	105	114	159	—	—	2	2	6.25	—
NF	110	170	122	93	93	109	112	124	187	187	172	2.5	2.5	7.32	7.14
—	96.5	118.5	100.9	90	91.5	95	99	102	123.5	125	119.5	1	1	1.03	1.01
NF	101.8	133.8	108.2	94	94	99	104	110	141	141	137	2	2	1.87	1.83
—	100.5	—	107.7	94	—	99	104	110	141	—	—	2	2	2.11	—
—	101.8	133.8	108.2	94	94	99	104	110	141	141	137	2	2	2.44	2.39
—	100.5	—	107.7	94	—	99	104	110	141	—	—	2	2	2.68	—
NF	108	156	117.5	98	98	106	110	119	167	167	160	2.5	2.5	4.54	4.44
—	108	—	118.4	98	—	106	110	119	167	—	—	2.5	2.5	4.81	—
—	108	156	117.5	98	98	106	110	119	167	167	160	2.5	2.5	6.7	6.57
—	108	—	118.4	98	—	106	110	119	167	—	—	2.5	2.5	7.16	—
—	103	127	107.8	96.5	98	101	106	109	132	133.5	129	1.5	1	1.33	1.31
NF	107	143	114.2	99	99	105	109	116	151	151	146	2	2	2.3	2.25
—	107	—	114.6	99	—	105	109	116	151	—	—	2	2	2.44	—
—	107	143	114.2	99	99	105	109	116	151	151	146	2	2	3.1	3.04
—	107	—	114.6	99	—	105	109	116	151	—	—	2	2	3.33	—
NF	115	165	125	103	103	111	117	127	177	177	169	2.5	2.5	5.3	5.18
—	113.5	—	124.7	103	—	111	117	127	177	—	—	2.5	2.5	5.72	—
—	115	165	125	103	103	111	117	127	177	177	169	2.5	2.5	7.95	7.79
—	113.5	—	124.7	103	—	111	117	127	177	—	—	2.5	2.5	8.56	—
—	108	132	112.8	101.5	103	106	111	114	137	138.5	134	1.5	1	1.4	1.38
NF	113.5	151.5	121	106	106	111	116	123	159	159	155	2	2	2.78	2.72
—	112.5	—	121	106	—	111	116	123	159	—	—	2	2	3.02	—

4) Does not apply to side of the outer ring rib of type NF bearings.

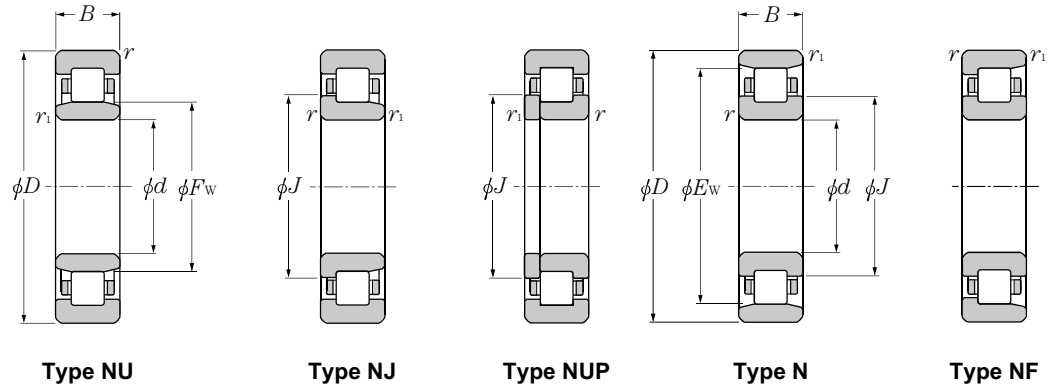

d 95 ~ 120mm

d	Boundary dimensions				Basic load ratings				Limiting speeds ¹⁾		Bearing numbers ²⁾			
	mm				dynamic	static	dynamic	static	min ⁻¹		type	type	type	type
	D	B	r _{s min} ³⁾	r _{1s min} ³⁾	C _r	C _{or}	C _r	C _{or}	grease	oil	NU	NJ	NUP	N
95	170	43	2.1	2.1	230	298	23 500	30 500	3 600	4 300	NU2219	NJ	NUP	N
	170	43	2.1	2.1	286	370	29 200	38 000	3 300	3 800	NU2219E	NJ	NUP	—
	200	45	3	3	259	285	26 400	29 500	3 400	4 000	NU319	NJ	NUP	N
	200	45	3	3	335	385	34 000	39 500	3 100	3 600	NU319E	NJ	NUP	—
	200	67	3	3	370	460	38 000	47 000	3 000	3 500	NU2319	NJ	NUP	N
	200	67	3	3	460	585	47 000	59 500	2 700	3 200	NU2319E	NJ	NUP	—
100	150	24	1.5	1.1	93.0	126	9 500	12 800	4 600	5 400	NU1020	NJ	NUP	N
	180	34	2.1	2.1	183	217	18 600	22 200	3 800	4 500	NU220	NJ	NUP	N
	180	34	2.1	2.1	249	305	25 400	31 000	3 500	4 100	NU220E	NJ	NUP	—
	180	46	2.1	2.1	258	340	26 300	34 500	3 500	4 100	NU2220	NJ	NUP	N
	180	46	2.1	2.1	335	445	34 000	45 500	3 100	3 600	NU2220E	NJ	NUP	—
	215	47	3	3	299	335	30 500	34 500	3 300	3 800	NU320	NJ	NUP	N
	215	47	3	3	380	425	38 500	43 500	2 900	3 500	NU320E	NJ	NUP	—
	215	73	3	3	410	505	42 000	51 500	2 900	3 400	NU2320	NJ	NUP	N
215	73	3	3	570	715	58 000	73 000	2 600	3 100	NU2320E	NJ	NUP	—	
105	160	26	2	1.1	105	142	10 700	14 500	4 300	5 100	NU1021	NJ	NUP	N
	190	36	2.1	2.1	201	241	20 500	24 600	3 600	4 300	NU221	NJ	NUP	N
	225	49	3	3	320	360	32 500	36 500	3 100	3 700	NU321	NJ	NUP	N
110	170	28	2	1.1	131	174	13 400	17 700	4 100	4 800	NU1022	NJ	NUP	N
	200	38	2.1	2.1	240	290	24 500	29 500	3 400	4 000	NU222	NJ	NUP	N
	200	38	2.1	2.1	293	365	29 800	37 000	3 100	3 700	NU222E	NJ	NUP	—
	200	53	2.1	2.1	320	415	32 500	42 000	3 100	3 700	NU2222	NJ	NUP	N
	200	53	2.1	2.1	385	515	39 000	52 500	2 800	3 300	NU2222E	NJ	NUP	—
	240	50	3	3	360	400	36 500	41 000	3 000	3 500	NU322	NJ	NUP	N
	240	50	3	3	450	525	46 000	53 500	2 700	3 100	NU322E	NJ	NUP	—
	240	80	3	3	605	790	61 500	80 500	2 600	3 100	NU2322	NJ	NUP	N
	240	80	3	3	675	880	69 000	89 500	2 400	2 800	NU2322E	NJ	NUP	—
120	180	28	2	1.1	139	191	14 100	19 500	3 800	4 400	NU1024	NJ	NUP	N
	215	40	2.1	2.1	260	320	26 500	32 500	3 200	3 700	NU224	NJ	NUP	N
	215	40	2.1	2.1	335	420	34 000	43 000	2 900	3 400	NU224E	NJ	NUP	—
	215	58	2.1	2.1	350	460	35 500	47 000	2 900	3 400	NU2224	NJ	NUP	N
	215	58	2.1	2.1	450	620	46 000	63 000	2 600	3 000	NU2224E	NJ	NUP	—
	260	55	3	3	450	510	46 000	52 000	2 700	3 200	NU324	NJ	NUP	N

1) This value achieved with machined cages; when pressed cages are used, 80% of this value is acceptable.

2) Production switched to E type only for bearing number for which there is no standard form.

3) Minimal allowable dimension for chamfer dimension r or r_1 .

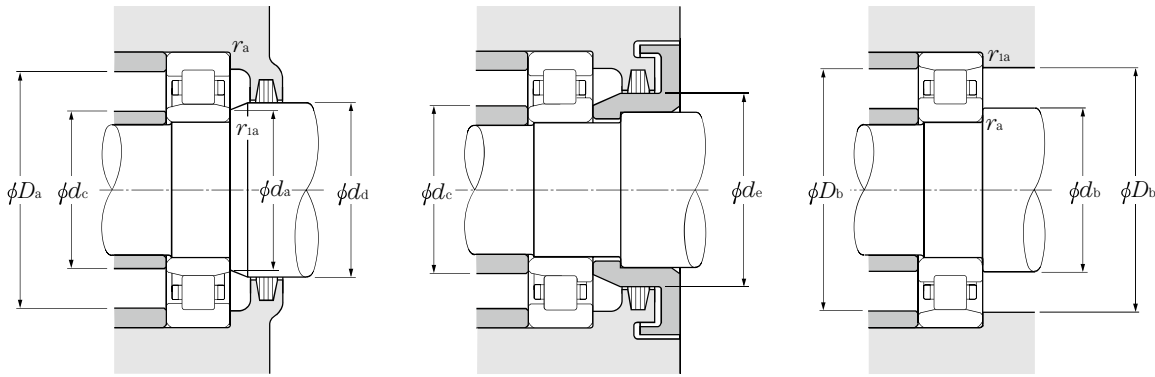

Dynamic equivalent radial load
 $P_r = F_r$

Static equivalent radial load
 $P_{0r} = F_r$

type	Dimensions			Abutment and fillet dimensions										Mass	
	F_w	E_w	J	d_a min	d_b min	d_c max	d_d min	d_e min	D_a max	D_b max	D_b min ⁴⁾	r_{as} max	r_{1as} max	type NU (approx.)	type N
NF	mm			mm										kg	
—	113.5	151.5	121	106	106	111	116	123	159	159	155	2	2	3.79	3.71
—	112.5	—	121	106	—	111	116	123	159	—	—	2	2	4.14	—
NF	121.5	173.5	132	108	108	119	124	134	187	187	178	2.5	2.5	6.13	5.99
—	121.5	—	132.7	108	—	119	124	134	187	—	—	2.5	2.5	6.62	—
—	121.5	173.5	132	108	108	119	124	134	187	187	178	2.5	2.5	9.2	9.02
—	121.5	—	132.7	108	—	119	124	134	187	—	—	2.5	2.5	9.8	—
—	113	137	117.8	106.5	108	111	116	119	142	143.5	139	1.5	1	1.45	1.43
NF	120	160	128	111	111	117	122	130	169	169	164	2	2	3.33	3.26
—	119	—	128	111	—	117	122	130	169	—	—	2	2	3.66	—
—	120	160	128	111	111	117	122	130	169	169	164	2	2	4.57	4.48
—	119	—	128	111	—	117	122	130	169	—	—	2	2	5.01	—
NF	129.5	185.5	140.5	113	113	125	132	143	202	202	190	2.5	2.5	7.49	7.32
—	127.5	—	140.3	113	—	125	132	143	202	—	—	2.5	2.5	8.57	—
—	129.5	185.5	140.5	113	113	125	132	143	202	202	190	2.5	2.5	11.7	11.5
—	127.5	—	140.3	113	—	125	132	143	202	—	—	2.5	2.5	12.8	—
—	119.5	145.5	124.7	111.5	114	118	122	126	151	153.5	147.5	2	1	1.84	1.81
NF	126.8	168.8	135	116	116	124	129	137	179	179	173	2	2	3.95	3.87
NF	135	195	147	118	118	132	137	149	212	212	199	2.5	2.5	8.53	8.33
—	125	155	131	116.5	119	124	128	132	161	163.5	157	2	1	2.33	2.3
NF	132.5	178.5	141.5	121	121	130	135	144	189	189	182	2	2	4.63	4.54
—	132.5	—	142.1	121	—	130	135	144	189	—	—	2	2	4.27	—
—	132.5	178.5	141.5	121	121	130	135	144	189	189	182	2	2	6.56	6.43
—	132.5	—	142.1	121	—	130	135	144	189	—	—	2	2	7.4	—
NF	143	207	155.5	123	123	140	145	158	227	227	211	2.5	2.5	10	9.77
—	143	—	156.6	123	—	140	145	158	227	—	—	2.5	2.5	11.1	—
—	143	207	155.5	123	123	140	145	158	227	227	211	2.5	2.5	17.1	16.8
—	143	—	156.6	123	—	140	145	158	227	—	—	2.5	2.5	19.4	—
—	135	165	141	126.5	129	134	138	142	171	173.5	167	2	1	2.44	2.4
NF	143.5	191.5	153	131	131	141	146	156	204	204	196	2	2	5.57	5.46
—	143.5	—	153.9	131	—	141	146	156	204	—	—	2	2	5.97	—
—	143.5	191.5	153	131	131	141	146	156	204	204	196	2	2	8.19	8.03
—	143.5	—	153.9	131	—	141	146	156	204	—	—	2	2	9.18	—
NF	154	226	168.5	133	133	151	156	171	247	247	230	2.5	2.5	12.8	12.5

4) Does not apply to side of the outer ring rib of type NF bearings.

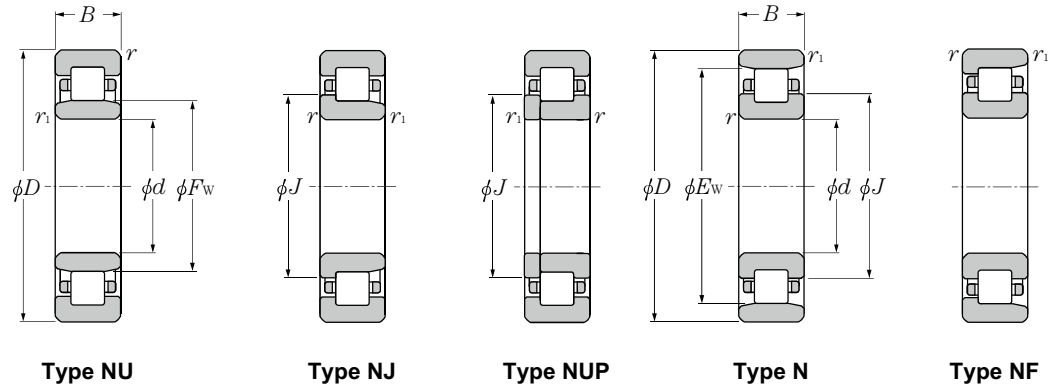

d 120 ~ 160mm

	Boundary dimensions					Basic load ratings				Limiting speeds ¹⁾		Bearing numbers ²⁾			
	d	D	mm B	r _{s min} ³⁾	r _{1s min} ³⁾	dynamic		static		grease	oil	type NU	type NJ	type NUP	type N
						C _r	C _{or}	C _r	C _{or}						
120	260	55	3	3	530	610	54 000	62 000	2 400	2 800	NU324E	NJ	NUP	—	
	260	86	3	3	710	920	72 500	93 500	2 400	2 800	NU2324	NJ	NUP	N	
	260	86	3	3	795	1 030	81 000	105 000	2 200	2 500	NU2324E	NJ	NUP	—	
130	200	33	2	1.1	172	238	17 500	24 200	3 400	4 000	NU1026	NJ	NUP	N	
	230	40	3	3	270	340	27 600	35 000	2 900	3 400	NU226	NJ	NUP	N	
	230	40	3	3	365	455	37 000	46 000	2 600	3 100	NU226E	NJ	NUP	—	
	230	64	3	3	380	530	38 500	54 000	2 600	3 100	NU2226	NJ	NUP	N	
	230	64	3	3	530	735	54 000	75 000	2 300	2 700	NU2226E	NJ	NUP	—	
	280	58	4	4	560	665	57 000	68 000	2 500	2 900	NU326	NJ	NUP	N	
	280	58	4	4	615	735	63 000	75 000	2 200	2 600	NU326E	NJ	NUP	—	
	280	93	4	4	840	1 130	85 500	115 000	2 200	2 600	NU2326	NJ	NUP	N	
	280	93	4	4	920	1 230	94 000	126 000	2 000	2 300	NU2326E	NJ	NUP	—	
140	210	33	2	1.1	176	250	17 900	25 500	3 200	3 800	NU1028	NJ	NUP	N	
	250	42	3	3	310	400	31 500	40 500	2 700	3 100	NU228	NJ	NUP	N	
	250	42	3	3	395	515	40 000	52 500	2 400	2 800	NU228E	NJ	NUP	—	
	250	68	3	3	445	635	45 500	64 500	2 400	2 800	NU2228	NJ	NUP	N	
	250	68	3	3	575	835	58 500	85 000	2 100	2 500	NU2228E	NJ	NUP	—	
	300	62	4	4	615	745	63 000	76 000	2 300	2 700	NU328	NJ	NUP	N	
	300	62	4	4	665	795	67 500	81 500	2 100	2 400	NU328E	NJ	NUP	—	
	300	102	4	4	920	1 250	94 000	127 000	2 000	2 300	NU2328	NJ	NUP	N	
	300	102	4	4	1 020	1 380	104 000	141 000	1 800	2 100	NU2328E	NJ	NUP	—	
150	225	35	2.1	1.5	202	294	20 600	29 900	3 000	3 500	NU1030	NJ	NUP	N	
	270	45	3	3	345	435	35 000	44 500	2 500	2 900	NU230	NJ	NUP	N	
	270	45	3	3	450	595	45 500	60 500	2 200	2 600	NU230E	NJ	NUP	—	
	270	73	3	3	500	710	51 000	72 500	2 200	2 600	NU2230	NJ	NUP	N	
	270	73	3	3	660	980	67 500	100 000	2 000	2 400	NU2230E	NJ	NUP	—	
	320	65	4	4	665	805	67 500	82 500	2 100	2 500	NU330	NJ	NUP	N	
	320	65	4	4	760	920	77 500	94 000	1 900	2 300	NU330E	NJ	NUP	—	
	320	108	4	4	1 020	1 400	104 000	143 000	1 900	2 200	NU2330	NJ	NUP	N	
	320	108	4	4	1 160	1 600	118 000	163 000	1 700	2 000	NU2330E	NJ	NUP	—	
160	240	38	2.1	1.5	238	340	24 200	35 000	2 800	3 300	NU1032	NJ	NUP	N	
	290	48	3	3	430	570	43 500	58 000	2 300	2 700	NU232	NJ	NUP	N	
	290	48	3	3	500	665	51 000	68 000	2 100	2 400	NU232E	NJ	NUP	—	

1) This value achieved with machined cages; when pressed cages are used, 80% of this value is acceptable.

2) Production switched to E type only for bearing number for which there is no standard form.

3) Minimal allowable dimension for chamfer dimension r or r_1 .

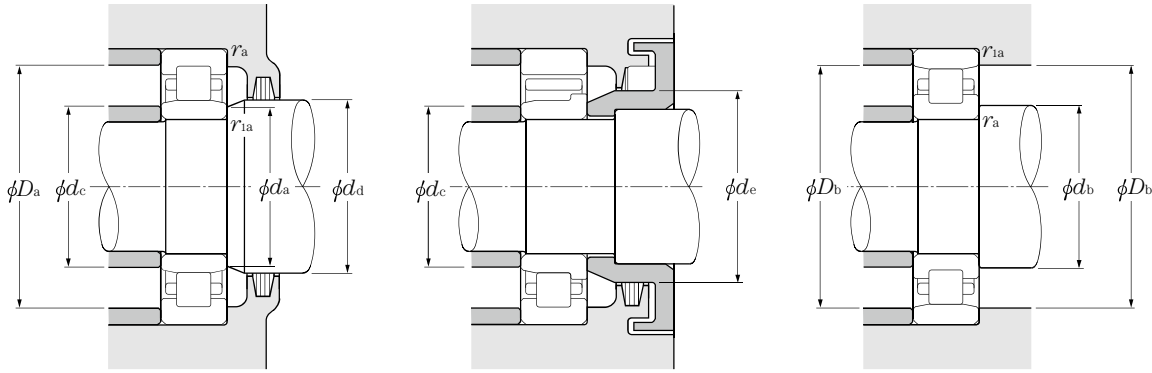

Dynamic equivalent radial load
 $P_r = F_r$

Static equivalent radial load
 $P_{or} = F_r$

type	Dimensions			Abutment and fillet dimensions										Mass	
	mm			mm										kg	
	F_w	E_w	J	d_a min	d_b min	d_c max	d_d min	d_e min	D_a max	D_b max	D_b min ⁴⁾	r_{as} max	r_{1as} max	type NU (approx.)	type N
—	154	—	169.2	133	—	151	156	171	247	—	—	2.5	2.5	13.9	—
—	154	226	168.5	133	133	151	156	171	247	247	230	2.5	2.5	21.5	21.1
—	154	—	169.2	133	—	151	156	171	247	—	—	2.5	2.5	26.1	—
—	148	182	154.8	136.5	139	146	151	156	191	193.5	184	2	1	3.69	3.63
NF	156	204	165.5	143	143	151	158	168	217	217	208	2.5	2.5	6.3	6.17
—	153.5	—	164.7	143	—	151	158	168	217	—	—	2.5	2.5	6.9	—
—	156	204	165.5	143	143	151	158	168	217	217	208	2.5	2.5	10.2	10
—	153.5	—	164.7	143	—	151	158	168	217	—	—	2.5	2.5	11.8	—
NF	167	243	182	146	146	164	169	184	264	264	247	3	3	17.4	17
—	167	—	183	146	—	164	169	184	264	—	—	3	3	19.4	—
—	167	243	182	146	146	164	169	184	264	264	247	3	3	26.9	26.4
—	167	—	183	146	—	164	169	184	264	—	—	3	3	30.9	—
—	158	192	164.8	146.5	149	156	161	166	201	203.5	194	2	1	4.05	3.98
NF	169	221	179.5	153	153	166	171	182	237	237	225	2.5	2.5	7.88	7.72
—	169	—	180.2	153	—	166	171	182	237	—	—	2.5	2.5	8.73	—
—	169	221	179.5	153	153	166	171	182	237	237	225	2.5	2.5	12.9	12.6
—	169	—	180.2	153	—	166	171	182	237	—	—	2.5	2.5	15.8	—
NF	180	260	196	156	156	176	182	198	284	284	265	3	3	21.2	20.7
—	180	—	196.8	156	—	176	182	198	284	—	—	3	3	23.2	—
—	180	260	196	156	156	176	182	198	284	284	265	3	3	33.8	33.1
—	180	—	196.8	156	—	176	182	198	284	—	—	3	3	38.7	—
—	169.5	205.5	176.7	158	161	167	173	178	214	217	207.5	2	1.5	4.77	4.7
NF	182	238	193	163	163	179	184	196	257	257	242	2.5	2.5	9.92	9.72
—	182	—	194	163	—	179	184	196	257	—	—	2.5	2.5	11	—
—	182	238	193	163	163	179	184	196	257	257	242	2.5	2.5	16.3	16
—	182	—	194	163	—	179	184	196	257	—	—	2.5	2.5	19.7	—
NF	193	277	210	166	166	190	195	213	304	304	282	3	3	25.3	24.7
—	193	—	211	166	—	190	195	213	304	—	—	3	3	28.4	—
—	193	277	210	166	166	190	195	213	304	304	282	3	3	40.6	39.8
—	193	—	211	166	—	190	195	213	304	—	—	3	3	47.2	—
—	180	220	188	168	171	178	184	189	229	232	222	2	1.5	5.9	5.81
NF	195	255	207	173	173	192	197	210	277	277	259	2.5	2.5	13.7	13.4
—	195	—	207.8	173	—	192	197	210	277	—	—	2.5	2.5	15.6	—

4) Does not apply to side of the outer ring rib of type **NF** bearings.

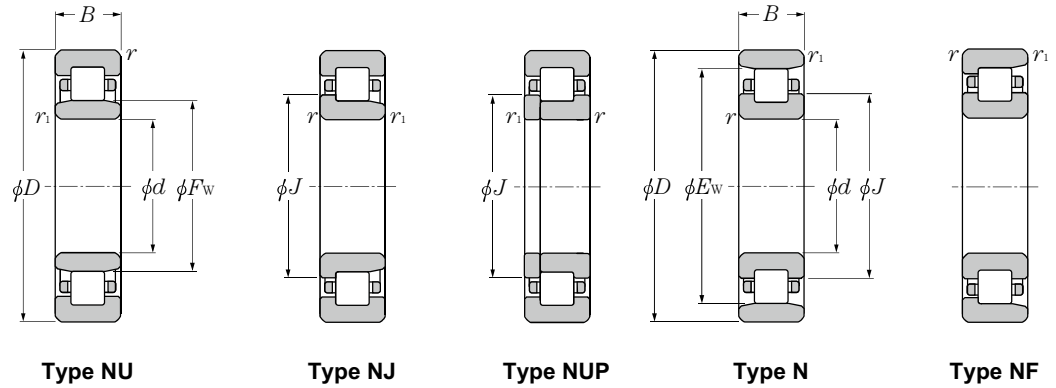

d 160 ~ 200mm

d	Boundary dimensions				Basic load ratings				Limiting speeds ¹⁾		Bearing numbers ²⁾			
	D	B	r _{s min} ³⁾	r _{1s min} ³⁾	dynamic		static		grease	oil	type	type	type	type
					C _r	C _{or}	C _r	C _{or}						
160	290	80	3	3	630	940	64 500	96 000	2 100	2 400	NU2232	NJ	NUP	N
	290	80	3	3	810	1 190	82 500	121 000	1 900	2 200	NU2232E	NJ	NUP	—
	340	68	4	4	700	875	71 000	89 500	2 000	2 300	NU332	NJ	NUP	N
	340	68	4	4	860	1 050	87 500	107 000	1 800	2 100	NU332E	NJ	NUP	—
	340	114	4	4	1 070	1 520	109 000	155 000	1 700	2 000	NU2332	NJ	NUP	N
	340	114	4	4	1 310	1 820	134 000	186 000	1 600	1 900	NU2332E	NJ	NUP	—
170	260	42	2.1	2.1	278	400	28 300	41 000	2 600	3 000	NU1034	NJ	NUP	N
	310	52	4	4	475	635	48 500	65 000	2 200	2 500	NU234	NJ	NUP	N
	310	52	4	4	605	800	61 500	81 500	2 000	2 300	NU234E	NJ	NUP	—
	310	86	4	4	715	1 080	73 000	110 000	2 000	2 300	NU2234	NJ	NUP	N
	310	86	4	4	965	1 410	98 500	144 000	1 800	2 100	NU2234E	NJ	NUP	—
	360	72	4	4	795	1 010	81 500	103 000	1 800	2 200	NU334	NJ	NUP	N
180	360	120	4	4	1 220	1 750	125 000	179 000	1 600	1 900	NU2334	NJ	NUP	N
	280	46	2.1	2.1	340	485	35 000	49 500	2 400	2 900	NU1036	NJ	NUP	N
	320	52	4	4	495	675	50 500	69 000	2 000	2 400	NU236	NJ	NUP	N
	320	52	4	4	625	850	64 000	87 000	1 800	2 200	NU236E	NJ	NUP	—
	320	86	4	4	745	1 140	76 000	117 000	1 800	2 200	NU2236	NJ	NUP	N
	320	86	4	4	1 010	1 510	103 000	154 000	1 600	1 900	NU2236E	NJ	NUP	—
190	380	75	4	4	905	1 150	92 000	118 000	1 700	2 000	NU336	NJ	NUP	N
	380	126	4	4	1 380	1 990	141 000	203 000	1 500	1 800	NU2336	NJ	NUP	N
	290	46	2.1	2.1	350	510	36 000	52 000	2 300	2 700	NU1038	NJ	NUP	N
	340	55	4	4	555	770	56 500	78 500	1 900	2 200	NU238	NJ	NUP	N
	340	55	4	4	695	955	71 000	97 500	1 700	2 000	NU238E	NJ	NUP	—
	340	92	4	4	830	1 290	84 500	131 000	1 700	2 000	NU2238	NJ	NUP	N
200	340	92	4	4	1 100	1 670	113 000	170 000	1 500	1 800	NU2238E	NJ	NUP	—
	400	78	5	5	975	1 260	99 500	129 000	1 600	1 900	NU338	NJ	NUP	N
	400	132	5	5	1 520	2 220	155 000	226 000	1 400	1 700	NU2338	NJ	NUP	N
	310	51	2.1	2.1	390	580	40 000	59 500	2 200	2 600	NU1040	NJ	NUP	N
	360	58	4	4	620	865	63 500	88 500	1 800	2 100	NU240	NJ	NUP	N
	360	58	4	4	765	1 060	78 000	108 000	1 600	1 900	NU240E	NJ	NUP	—
200	360	98	4	4	925	1 440	94 000	147 000	1 600	1 900	NU2240	NJ	NUP	N
	360	98	4	4	1 220	1 870	125 000	191 000	1 500	1 700	NU2240E	NJ	NUP	—
	420	80	5	5	975	1 270	99 500	130 000	1 500	1 800	NU340	NJ	NUP	N

1) This value achieved with machined cages; when pressed cages are used, 80% of this value is acceptable.

2) Production switched to E type only for bearing number for which there is no standard form.

3) Minimal allowable dimension for chamfer dimension r or r_1 .

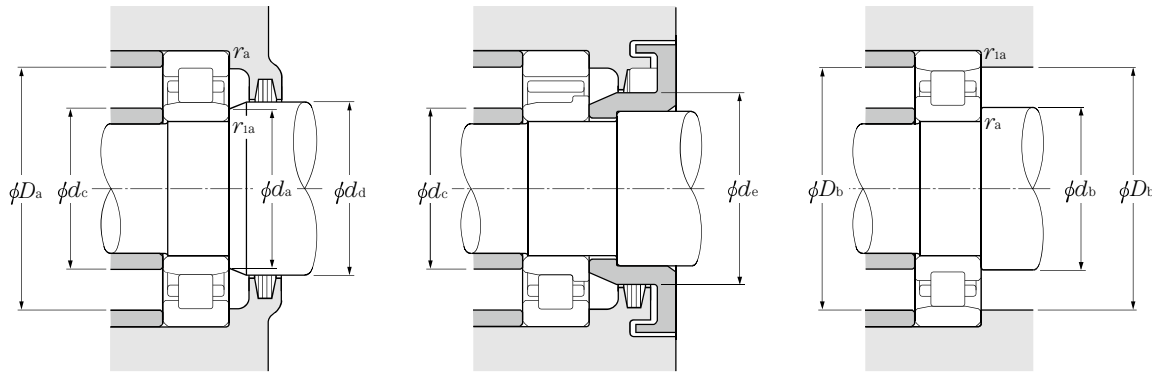

Dynamic equivalent radial load
 $P_r = F_r$

Static equivalent radial load
 $P_{or} = F_r$

type NF	Dimensions			Abutment and fillet dimensions										Mass	
	mm			mm										kg	
	F_w	E_w	J	d_a min	d_b min	d_c max	d_d min	d_e min	D_a max	D_b max	D_b min ⁴⁾	r_{as} max	r_{1as} max	type NU (approx.)	type N
—	195	255	207	173	173	192	197	210	277	277	259	2.5	2.5	22	21.6
—	193	—	206.6	173	—	192	197	210	277	—	—	2.5	2.5	25.1	—
NF	208	292	225	176	176	200	211	228	324	324	297	3	3	31.3	30.6
—	204	—	223.2	176	—	200	211	228	324	—	—	3	3	34	—
—	208	292	225	176	176	200	211	228	324	324	297	3	3	50.5	49.5
—	204	—	223.2	176	—	200	211	228	324	—	—	3	3	56	—
—	193	237	201.8	181	181	190	197	203	249	249	239	2	2	7.88	7.76
NF	208	272	220.5	186	186	204	211	223	294	294	277	3	3	17	16.7
—	207	—	221.4	186	—	204	211	223	294	—	—	3	3	19.6	—
—	208	272	220.5	186	186	204	211	223	294	294	277	3	3	27.2	26.7
—	205	—	220.2	186	—	204	211	223	294	—	—	3	3	31	—
NF	220	310	238	186	186	216	223	241	344	344	315	3	3	37	36.1
—	220	310	238	186	186	216	223	241	344	344	315	3	3	59.5	58.3
—	205	255	215	191	191	203	209	216	269	269	257	2	2	10.3	10.1
NF	218	282	230.5	196	196	214	221	233	304	304	287	3	3	17.7	17.3
—	217	—	231.4	196	—	214	221	233	304	—	—	3	3	20.4	—
—	218	282	230.5	196	196	214	221	233	304	304	287	3	3	28.4	27.8
—	215	—	230.2	196	—	214	221	233	304	—	—	3	3	31.9	—
NF	232	328	252	196	196	227	235	255	364	364	333	3	3	44.2	43.2
—	232	328	252	196	196	227	235	255	364	364	333	3	3	69.5	68.1
—	215	265	225	201	201	213	219	226	279	279	267	2	2	10.7	10.5
NF	231	299	244.5	206	206	227	234	247	324	324	304	3	3	21.3	20.8
—	230	—	245.2	206	—	227	234	247	324	—	—	3	3	24.2	—
—	231	299	244.5	206	206	227	234	247	324	324	304	3	3	34.4	33.7
—	228	—	244	206	—	227	234	247	324	—	—	3	3	39.5	—
NF	245	345	265	210	210	240	248	268	380	380	351	4	4	49.4	48.3
—	245	345	265	210	210	240	248	268	380	380	351	4	4	80.5	78.9
—	229	281	239.4	211	211	226	233	241	299	299	283	2	2	13.9	13.7
NF	244	316	258	216	216	240	247	261	344	344	321	3	3	25.3	24.8
—	243	—	259	216	—	240	247	261	344	—	—	3	3	28.1	—
—	244	316	258	216	216	240	247	261	344	344	321	3	3	41.3	40.5
—	241	—	257.8	216	—	240	247	261	344	—	—	3	3	47.8	—
NF	260	360	280	220	220	254	263	283	400	400	366	4	4	55.8	54.5

4) Does not apply to side of the outer ring rib of type NF bearings.

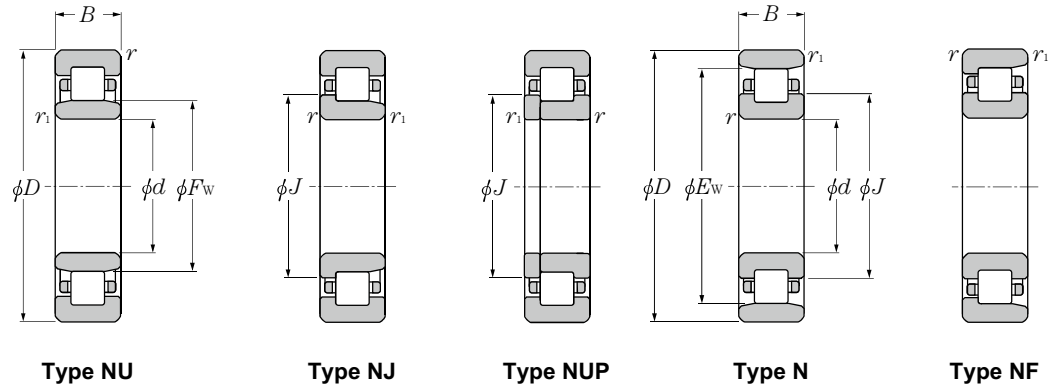

d 200 ~ 360mm

d	Boundary dimensions					Basic load ratings				Limiting speeds ¹⁾		Bearing numbers ²⁾			
	D	mm B	r _{s min} ³⁾	r _{1s min} ³⁾	C _r	dynamic	static	dynamic	static	grease	oil	type NU	type NJ	type NUP	type N
						kN		kgf							
200	420	138	5	5	1 510	2 240	154 000	229 000	1 400	1 600	NU2340	NJ	NUP	N	
	340	56	3	3	500	750	51 000	76 500	2 000	2 300	NU1044	NJ	NUP	N	
220	400	65	4	4	760	1 080	77 500	110 000	1 600	1 900	NU244	NJ	NUP	N	
	400	108	4	4	1 140	1 810	116 000	184 000	1 500	1 700	NU2244	NJ	NUP	N	
	460	88	5	5	1 190	1 570	122 000	161 000	1 400	1 600	NU344	NJ	NUP	N	
	460	145	5	5	1 780	2 620	181 000	268 000	1 200	1 400	NU2344	NJ	NUP	N	
240	360	56	3	3	530	820	54 000	83 500	1 800	2 100	NU1048	NJ	NUP	N	
	440	72	4	4	935	1 340	95 500	136 000	1 500	1 700	NU248	NJ	NUP	N	
	440	120	4	4	1 440	2 320	146 000	236 000	1 300	1 600	NU2248	NJ	NUP	N	
	500	95	5	5	1 430	1 950	146 000	198 000	1 300	1 500	NU348	NJ	NUP	N	
	500	155	5	5	2 100	3 200	214 000	325 000	1 100	1 300	NU2348	NJ	NUP	N	
260	400	65	4	4	645	1 000	65 500	102 000	1 600	1 900	NU1052	NJ	NUP	N	
	480	80	5	5	1 150	1 660	117 000	170 000	1 300	1 600	NU252	NJ	NUP	N	
	480	130	5	5	1 780	2 930	182 000	299 000	1 200	1 400	NU2252	NJ	NUP	N	
	540	102	6	6	1 620	2 230	165 000	228 000	1 200	1 400	NU352	NJ	NUP	N	
	540	165	6	6	2 340	3 600	239 000	365 000	1 000	1 200	NU2352	NJ	NUP	N	
280	420	65	4	4	660	1 050	67 000	107 000	1 500	1 800	NU1056	NJ	NUP	N	
	500	80	5	5	1 190	1 760	121 000	180 000	1 200	1 400	NU256	NJ	NUP	N	
	500	130	5	5	1 840	3 100	188 000	315 000	1 100	1 300	NU2256	NJ	NUP	N	
	580	108	6	6	1 820	2 540	185 000	259 000	1 100	1 200	NU356	NJ	NUP	N	
	580	175	6	6	2 700	4 250	275 000	430 000	920	1 100	NU2356	NJ	NUP	N	
300	460	74	4	4	855	1 340	87 000	137 000	1 400	1 600	NU1060	NJ	NUP	N	
	540	85	5	5	1 400	2 070	143 000	211 000	1 100	1 300	NU260	NJ	NUP	N	
	540	140	5	5	2 180	3 650	223 000	370 000	1 000	1 200	NU2260	NJ	NUP	N	
320	480	74	4	4	875	1 410	89 500	143 000	1 300	1 500	NU1064	NJ	NUP	N	
	580	92	5	5	1 600	2 390	164 000	244 000	1 000	1 200	NU264	NJ	NUP	N	
	580	150	5	5	2 550	4 350	260 000	445 000	950	1 100	NU2264	NJ	NUP	N	
340	520	82	5	5	1 050	1 670	107 000	170 000	1 200	1 400	NU1068	NJ	NUP	N	
360	540	82	5	5	1 080	1 750	110 000	179 000	1 100	1 300	NU1072	NJ	NUP	N	

1) This value achieved with machined cages; when pressed cages are used, 80% of this value is acceptable.

2) Production switched to E type only for bearing number for which there is no standard form.

3) Minimal allowable dimension for chamfer dimension r or r_1 .

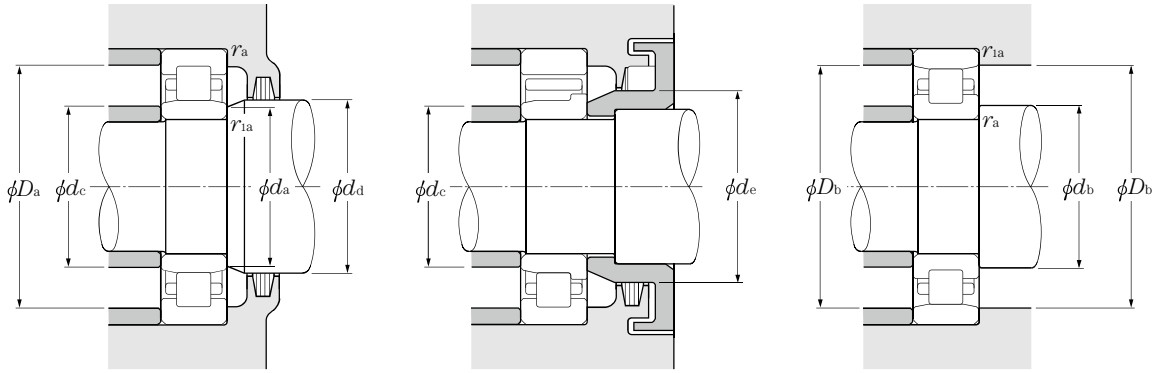

Dynamic equivalent radial load
 $P_r = F_r$

Static equivalent radial load
 $P_{or} = F_r$

type	Dimensions			Abutment and fillet dimensions										Mass	
	F_w	E_w	J	d_a min	d_b min	d_c max	d_d min	d_e min	D_a max	D_b max	D_b min ⁴⁾	r_{as} max	r_{1as} max	type NU (approx.)	type N
—	260	360	280	220	220	254	263	283	400	400	366	4	4	92.6	90.7
—	250	310	262	233	233	248	254	264	327	327	313	2.5	2.5	18.2	17.9
NF	270	350	286	236	236	266	273	289	384	384	355	3	3	37.7	37
—	270	350	286	236	236	266	273	289	384	384	355	3	3	59	57.8
NF	284	396	307	240	240	279	287	307	440	440	402	4	4	73.4	71.7
—	284	396	307	240	240	279	287	307	440	440	402	4	4	116	114
—	270	330	282	253	253	268	275	284	347	347	333	2.5	2.5	19.6	19.3
NF	295	385	313	256	256	293	298	316	424	424	390	3	3	50.2	49.2
—	295	385	313	256	256	293	298	316	424	424	390	3	3	80	78.4
NF	310	430	335	260	260	305	313	333	480	480	436	4	4	93.4	91.3
—	310	430	335	260	260	305	313	333	480	480	436	4	4	147	144
—	296	364	309.6	276	276	292	300	312	384	384	367	3	3	29.1	28.7
NF	320	420	340	280	280	318	323	343	460	460	426	4	4	66.9	65.6
—	320	420	340	280	280	318	323	343	460	460	426	4	4	104	102
NF	336	464	362	284	284	331	339	359	516	516	471	5	5	117	114
—	336	464	362	284	284	331	339	359	516	516	471	5	5	182	178
—	316	384	329.6	296	296	312	320	332	404	404	387	3	3	30.9	30.4
NF	340	440	360	300	300	336	343	365	480	480	446	4	4	70.8	69.4
—	340	440	360	300	300	336	343	365	480	480	446	4	4	109	107
NF	362	498	390	304	304	356	366	386	556	556	505	5	5	142	139
—	362	498	390	304	304	356	366	386	556	556	505	5	5	222	218
—	340	420	356	316	316	336	344	358	444	444	423	3	3	43.6	42.9
NF	364	476	387	320	320	361	368	392	520	520	482	4	4	88.2	86.4
—	364	476	387	320	320	361	368	392	520	520	482	4	4	138	135
—	360	440	376	336	336	356	364	378	464	464	443	3	3	46	45.3
NF	390	510	415	340	340	386	393	419	560	560	516	4	4	111	109
—	390	510	415	340	340	386	393	419	560	560	516	4	4	172	168
—	385	475	403	360	360	381	390	405	500	500	479	4	4	61.8	60.8
—	405	495	423	380	380	401	410	425	520	520	499	4	4	64.7	63.7

4) Does not apply to side of the outer ring rib of type **NF** bearings.

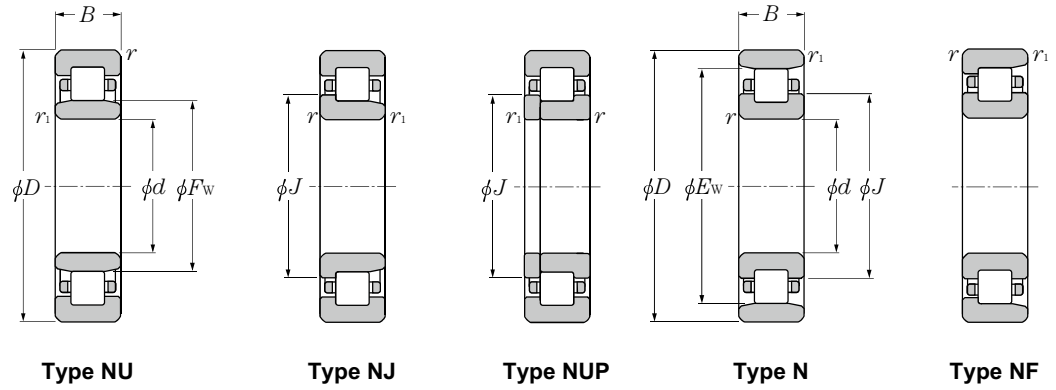

d 380 ~ 500mm

Boundary dimensions					Basic load ratings				Limiting speeds ¹⁾		Bearing numbers ²⁾			
d	D	mm B	$r_{s \min}^{3)}$	$r_{is \min}^{3)}$	dynamic		static		grease	oil	type NU	type NJ	type NUP	type N
					C_r	C_{or}	C_r	C_{or}						
380	560	82	5	5	1 100	1 840	112 000	187 000	1 100	1 200	NU1076	NJ	NUP	N
400	600	90	5	5	1 320	2 190	134 000	223 000	990	1 200	NU1080	NJ	NUP	N
420	620	90	5	5	1 350	2 290	138 000	233 000	950	1 100	NU1084	NJ	NUP	N
440	650	94	6	6	1 430	2 430	146 000	248 000	900	1 100	NU1088	NJ	NUP	N
460	680	100	6	6	1 540	2 630	157 000	269 000	850	1 000	NU1092	NJ	NUP	N
480	700	100	6	6	1 580	2 750	161 000	280 000	810	960	NU1096	NJ	NUP	N
500	720	100	6	6	1 610	2 870	164 000	292 000	770	910	NU10/500	NJ	NUP	N

1) This value achieved with machined cages; when pressed cages are used, 80% of this value is acceptable.

2) Production switched to E type only for bearing number for which there is no standard form.

3) Minimal allowable dimension for chamfer dimension r or r_1 .

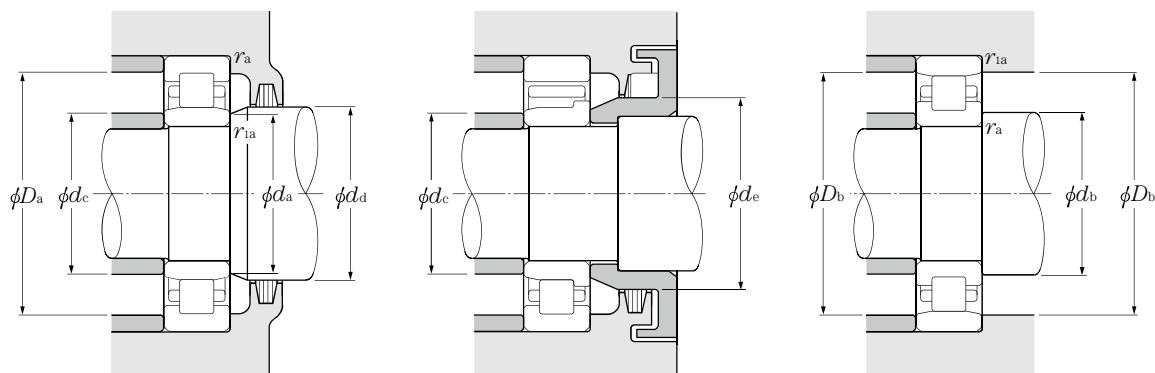

Dynamic equivalent radial load
 $P_r = F_r$

Static equivalent radial load
 $P_{or} = F_r$

type NF	Dimensions			Abutment and fillet dimensions										Mass	
	mm			mm										kg	
	F_w	E_w	J	d_a min	d_b min	d_c max	d_d min	d_e min	D_a max	D_b max	D_b min ⁴⁾	r_{as} max	r_{1as} max	type NU (approx.)	type N
—	425	515	443	400	400	421	430	445	540	540	519	4	4	67.5	66.5
—	450	550	470	420	420	446	455	473	580	580	554	4	4	87.6	86.3
—	470	570	490	440	440	466	475	493	600	600	574	4	4	91	89.6
—	493	597	513.8	464	464	488	499	517	626	626	602	5	5	105	103
—	516	624	537.6	484	484	511	522	541	656	656	629	5	5	122	120
—	536	644	557.6	504	504	531	542	561	676	676	649	5	5	126	124
—	556	664	577.6	524	524	551	562	581	696	696	669	5	5	130	128

4) Does not apply to side of the outer ring rib of type NF bearings.